

CERTIFICATION

Pursuant to Section 86, Indian Act RSC 1985 C.I-5 and amendments thereto, I certify that the attached copy of the "Capital Expenditure By-law No. 11-TX-09" of the Westbank First Nation dated March 9, 2012 is a true copy of the said by-law.

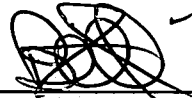

**Bill Guerin, Director
Community Development,
a Superintendent as defined in
Section 2(1) Indian Act RSC 1985**

Ministre des Affaires indiennes et
du Nord canadien et interlocuteur fédéral
auprès des Métis et des Indiens non inscrits



Minister of Indian Affairs and
Northern Development and Federal Interlocutor
for Métis and Non-Status Indians

Ottawa, Canada K1A 0H4

I, Minister of Aboriginal Affairs and Northern Development, HEREBY
APPROVE, pursuant to section 83 of the *Indian Act*, the following by-law
made by the Westbank First Nation, in the Province of British Columbia, at
a meeting held on the 6th day of February 2012.

**Westbank First Nation
Capital Expenditure By-law No. 11-TX-10**

A handwritten signature in black ink, appearing to be 'A. Man...'.

Dated at Ottawa, Ontario, this 9th day of March 2012.

Canada

**WESTBANK FIRST NATION
CAPITAL EXPENDITURE BY-LAW NO. 11-TX-10**

To authorize the expenditure of a maximum of Three Hundred Thousand Dollars (\$300,000.00) from money raised pursuant to section 83(1) of the *Indian Act*, for the purposes of installing offsite improvements to "the beach" within the Tsinstikeptum Indian Reserve No.9.

WHEREAS: Pursuant to Section 83(1) of the *Indian Act* and Westbank First Nation's inherent right of self-government, Westbank First Nation has enacted the Westbank First Nation Property Taxation By-law, 95-TX-08 (the "**Taxation By-law**");

- A. Pursuant to the Westbank First Nation Expenditure By-law, 1995, amended by By-law 97-TX-03 (the "**Expenditure By-law**"), Westbank First Nation is authorized to expend moneys raised pursuant to the Taxation By-law for local purposes, including the provision of local services on reserve and capital projects;
- B. In accordance with section 12(3)(l) of the Taxation By-law, Westbank First Nation annually deposits ten percent (10%) of annual gross taxes into a "cumulative capital projects fund", (the "**Cumulative Fund**") to be used from time to time for such capital projects as may be authorized by a separate by-law;
- C. In accordance with subsection 4.4 of the WFN Expenditure By-law 1995, all surplus monies remaining in the Taxation Fund at the end of the Fiscal Year specified in the Expenditure By-law Annual Budget Schedule may be transferred into the Stabilization Fund, and may be applied towards the operation and administration costs for the next Fiscal Year overruns on existing Capital projects or for any other contingencies (the "**Stabilization Fund**");
- D. Westbank First Nation deems it desirable and in the best interest of the community to proceed with the installation of offsite improvements which include multi-use walking path, parking lot paving and underground irrigation on Tsinstikeptum Indian Reserve No.9 according to the schematics and plan attached (**Schedule A**), with a proposed estimated cost of Three Hundred Thousand Dollars (\$300,000) which will be contributed from the Cumulative Fund.
- E. Funding for the offsite improvements on Tsinstikeptum Indian Reserve No.9 will be Three Hundred Thousand Dollars (\$300,000) drawn from the Cumulative Fund, funds raised pursuant to section 83(1) of the *Indian Act*.

NOW THEREFORE, the Council of Westbank First Nation hereby enacts the following By-law;

SHORT TITLE

1. This By-law may be cited for all purposes as the IR No.9 Offsite Improvements Beach Capital Expenditure By-law No. 11-TX-10.

EXPENDITURE AUTHORIZATION

2. Westbank First Nation hereby acknowledges that it is in the best interests of the community to proceed with the Offsite Improvements Beach Project on Tsinstikeptum Indian Reserve No.9 according to the schematics and plan attached (**Schedule A**) (the "IR No.9 Offsite Improvements Beach Project");
3. Westbank First Nation hereby approves the expenditure of not more than Three Hundred Thousand Dollars (\$300,000) on the IR No.9 Offsite Improvements Beach Project with up to Three Hundred Thousand Dollars (300,000) to be drawn from the Cumulative fund;
4. Westbank First Nation authorization of this capital expenditure includes all external expenditures related to the project including architects, designers, consultants, engineers, contractors, permits, and suppliers of all related goods and materials but will not include any allocation of WFN internal costs, overhead, or implicit interest.
5. Any of the project funds not expended on the "IR No.9 Offsite Improvement Beach Project" or incidental costs related thereto, will be reimbursed to and deposited in the Cumulative Fund upon completion of the IR No.9 Offsite Improvements Beach Project.

EFFECTIVE

This By-law comes into full force and effect upon approval by the Minister of Aboriginal Affairs and Northern Development.

BE IT HEREBY RESOLVED AND AGREED:

That this By-law, entitled IR#9 Offsite Improvements Beach Capital Expenditure Bylaw No. 11-TX-10 being read for the first, second and third and final time by the Council of Westbank First Nation held at duly convened meetings.

1st Reading

Kelowna, British Columbia, this 19th day of December 2011.

2nd Reading

Exempt from second reading as per section 60.9 of Westbank First Nation Constitution pertaining to enactment of a Local Revenue Law.

3rd Reading

Kelowna, British Columbia, this 6th day of February 2012.

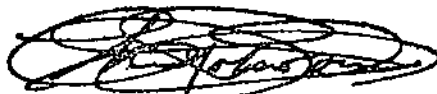

Chief Robert Louie



Councillor Michael De Guevara

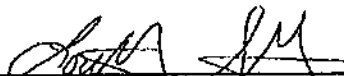

Councillor Loretta Swite-Ghostkeeper



Councillor Mick Werstuik



Councillor Lorrie Hogaboam

IR#9 Offsite Improvements Beach Capital Expenditure By-law No. 11-TX-10

COST SUMMARY

ITEM	WFN (LGS) LOCAL GOVERNMENT SERVICES	YEAR OF EXPENDITURE
IR#9 Offsite Beach	\$ 300,000	2012
	\$	
<u>TOTAL</u>	<u>\$ 300,000</u>	

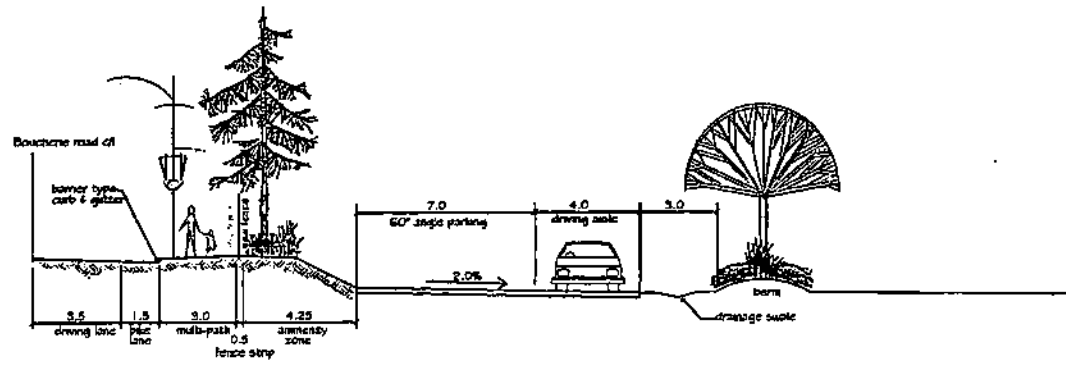
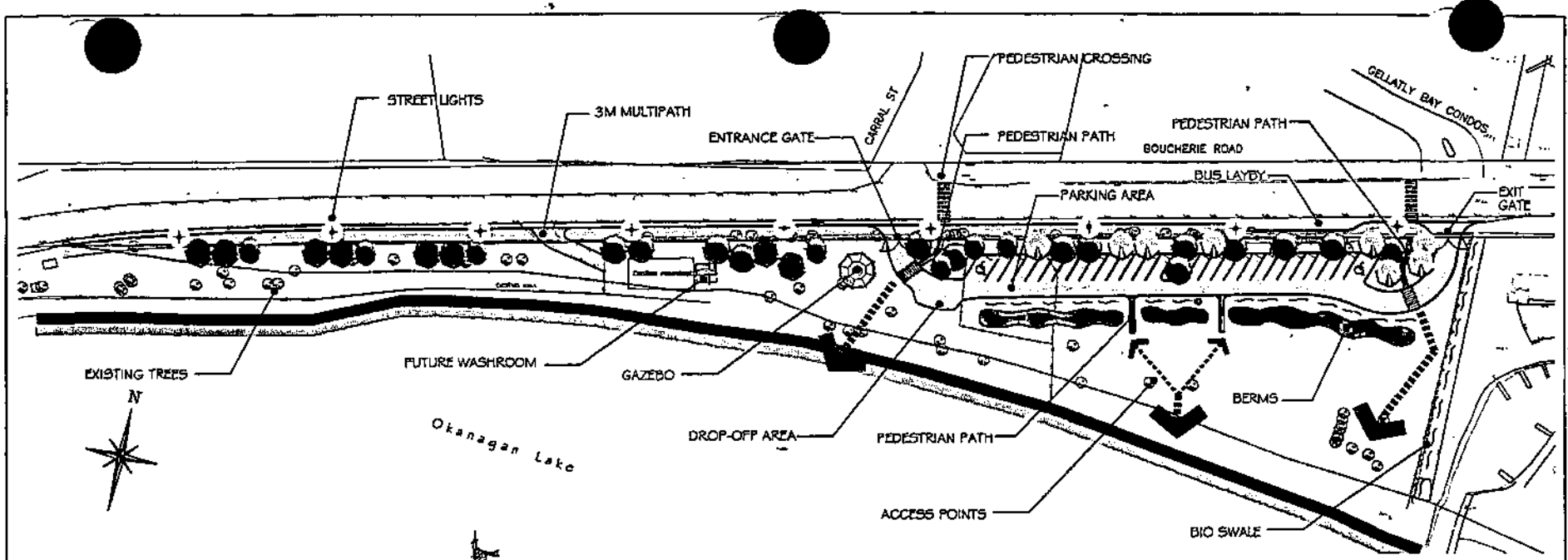

TYPICAL SITE SECTION

WESTBANK FIRST NATIONS
I.R.#9 BEACH & PARKING IMPROVEMENTS
OVERALL WORKS

PROTECH
CONSULTANTS LTD.
2 - 5000 16th St. W.

Schedule A

Ernest Jack

From: Laurie Bowen
Sent: Monday, January 16, 2012 5:48 PM
To: Dan Brown; Ernest Jack
Cc: Brian Conner; Elise Petersen
Subject: Draft Minutes re Capital Expenditure Bylaws

Hi All,
Below, for your review, are the draft minutes from today's General Council Meeting re: the Capital Expenditure bylaws.
Laurie

	<u>Third Reading of Capital Expenditure Bylaws</u> <u>No. 11-TX-09 - Electronic Message Board</u> (Staff Report to Council from D. Brown dated January 11, 2012 is attached to these minutes as Exhibit "N.")
<i>D. Brown</i>	Overviewed his report with Council.
RESOLUTION 120116-11	MOVED BY COUNCILLOR DE GUEVARA Seconded by Councillor Werstuik THAT Council hereby gives Third Reading to Westbank First Nation Capital Expenditure Bylaw No. 11-TX-09. CARRIED
	<u>No. 11-TX-10 - IR /9 Beach Improvements</u> (Staff Report to Council from D. Brown dated January 11, 2012 is attached to these minutes as Exhibit "O.")
<i>D. Brown</i>	Overviewed his report with Council.
	Council noted the comments made by the Advisory Council.
RESOLUTION 120116-12	MOVED BY COUNCILLOR DE GUEVARA Seconded by Councillor Werstuik THAT Council hereby gives Third Reading to Westbank First Nation Capital Expenditure Bylaw No. 11-TX-10.



	<u>Rent Increases in Manufactured Home Parks (Continued)</u>
Staff entered:	B. Conner and E. Jack entered the meeting.
<i>B. Semeniuk</i>	The rent increases are in excess of the cost of living increase.
	The Advisory Council agreed that B. Semeniuk, T. Turcan and R. De Guevara are to meet with WFN's Legal Counsel, Marcus Hadley, on this issue.
	<u>Budget Review for 2012</u> (WFN Local Government Services 2012/2013 Provisional Property Tax Budget dated February 14, 2012, 2012 Examples on Gross Taxes (Before Home Owner Grants) and WFN Taxation Estimated Tax Rates by Class 2012/2013 Provisional Budget are attached to these minutes as Exhibit "D.")
<i>B. Conner and E. Jack</i>	Overviewed the budget with the Advisory Council.
	The Advisory Council agreed to review the budget again in a couple of weeks once a couple of other details are worked out.
FOR YOUR INFORMATION	<u>Third Reading of Capital Expenditure Bylaws</u> (General Council Meeting Minutes from January 16, 2012 are attached to these minutes as Exhibit "E.")
<i>E. Jack</i>	These bylaws had to be revised to reflect the new name of Indian Affairs which is now Aboriginal Affairs. They were resigned with this change.
	The Advisory Council express their dissatisfaction with the Advisory Council not receiving feedback from Council on comments they make regarding laws they are asked to review, such as the comments they made regarding the IR #9 Beach Improvements.
Staff left:	B. Conner and E. Jack left the meeting.
NEW BUSINESS (Continued)	<u>Rent Increases in Manufactured Home Parks</u> (Continued)
	The Advisory Council agreed that B. Semeniuk is to find out if the District of West Kelowna ("DWK") requires the landlords of mobile home parks to provide their tenants with a formal DWK Notice of Rent Increase.